

ROTORUA MODEL AIRCRAFT CLUB (INC)

JULY 2024 NEWSLETTER

Secretary Andy Watson

Email: top.place@xtra.co.nz Ph 0274 856553

http://www.rotoruumac.org.nz/wordpress_Z



AOTEAROA
GAMING
TRUST



Rotorua Trust
MŌ TĀTAU KATOĀ



Welcome to the July 2024 newsletter

Grant Application Success

The Club applied to the Rotorua Trust last month for an operational grant. We have been successful in being granted the full amount applied for. This will basically cover our rent, insurance and mowing costs. Great news.

Tauranga Auction

Last month's Tauranga auction was attended by a few of our members. Andy and Dave had a clean out of the club house and sold a pile of gear which has swollen the clubs bank account. Tim came back with a foam aerobatic model which was test flown on the 30th. After a few set up changes it was performing very nicely.

New Member

Welcome to new member Dylan Pain. Dylan was a member of the Ashurst club several years ago and is getting back into it. He managed to pick up an almost new Futaba radio which he has been using as a bubby box with the club trainer. He has now purchased the Sky Raider the Club had for sale and is installing his radio.

Cold Wet or Cold and Wet

Weather wise it's not been good although we did have two days on the 21st and 22nd when the rain and wind stopped. A big turnout both days saw all sorts of models flying about that we haven't seen for a while. The 30th also turned out dead calm but activities were curtailed by fog until 11am. Meanwhile the midweekers have spent a lot of time at 3rd Place Cafe drinking coffee. Sunday 7 July saw three fliers take on the wind. Dylan

was back in the air again and flying well in the rough conditions. Graham was sorting out a helicopter after replacing the ECS with a more grunty one. And John had his low wing Hummingbird going well. By mid day we were all frozen and headed home with our models undamaged.

NOVEMBER VINTAGE/CLASSIC WEEKEND

Future Event

Rotorua Vintage and Classic Weekend

16th / 17th Nov 2024



Preparations are well underway for this new event on the flying calendar at a venue never previously used. With more than three months to prepare - no excuses!

Take a mini-break over the weekend of 16th and 17th November to fly Vintage and to explore the Rotorua thermal area.

Non-competition with one exception, see below*. Fly your Vintage and Classic models that we don't usually see at competitions - and the ones we do see as well.

With the interest in single channel emulation 2.4 radios, this will be an opportunity to fly these if you are already involved, or to see them flown if you are still multi-channel.

* For something new there will be a Special Competition for the Modelair Hummingbird :

Hummingbird R/C 1/2A Texaco

Got your Hummingbird organised? We have four starters so far - there's room for more!!

Organiser: John Ryan
johnrt6k@gmail.com

Last month we featured a copy of the Humming bird plan. We have now seen three flying. All three variations shown on the plan.

High wing cabin, shoulder wing and low wing. All three fly equally as well so if you are going to build one chose any version.

The plan shows 100mm dihedral under each wing tip. This makes for a very stable free flight model but for R/C use we found 65mm under each tip makes for much smoother flying.



A Flock of Hummingbirds



BUTTON MAN

Colin had the misfortune to crash into the jungle recently. Brent managed to see some remains stuck in a bush and managed to get this photo of the debris. From the trail of destruction and the noise it made it must have been traveling close to the sound barrier. Luckily all the bits were retrieved!



A WORD FROM DAVE

As John reported in the June bulletin, the first of our fun events took place, the four participants having a great time doing it. Other such events such as dead stick landings, spot landings etc are being planned. These will be run as casual events for those who want to have a go and the support is there....if time permits on the day.

Random stuff

This servo configuration was displayed in the May Bulletin as a “quiz item” as to what type of control surfaces/model it would apply to. Most of you would have figured it out by now, however for the few that haven’t it is for a “V tail” configuration like that of a Beechcraft Bonanza.

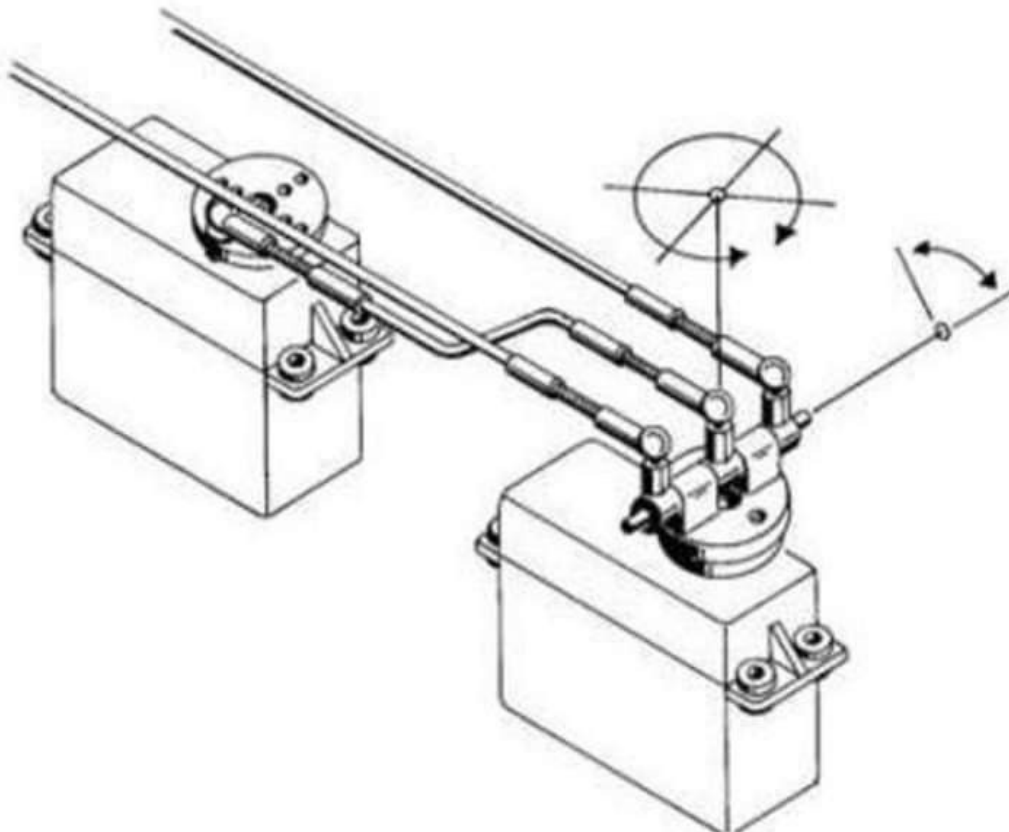

There is no better pastime than spending time (and money?) on model aircraft stuff,



although the mancave can be a bit cool during winter. There's always the kitchen table, or not.

That's all from me for this month.

Cheers

Dave Little

FOR SALE

The Club has a beginners model for sale

Arising Star

- Complete with servos and ASP 46
- Test flown and ready to fly just requires a receiver and battery pack.
- Another good beginners model.
- Has had a bit of use but has plenty of life left



If you are interested in either of these models we can arrange a buddy box trial flight.

Contact John on 020 4118 5597

COMING EVENTS

July 20/21

Glider towing Matamata

Nov 16/17

Rotorua Vintage/Classic Rally